

MA-17 series

[Absolute]



Outside dimensions

MAS-17

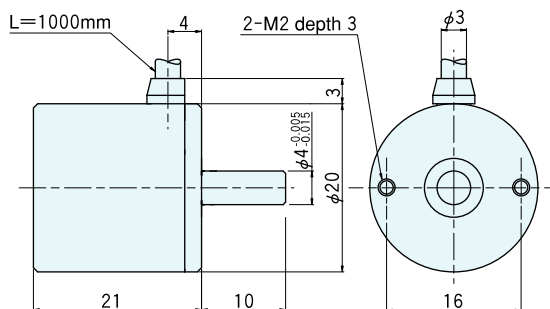

MAH-17

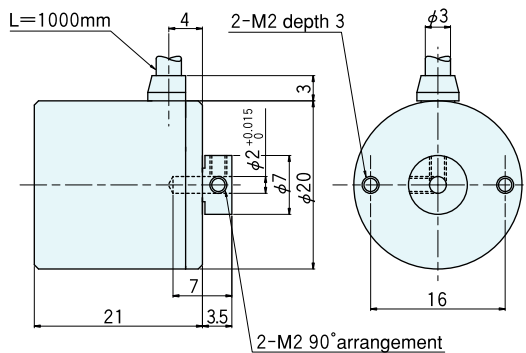

Output circuit diagram

Each output circuit

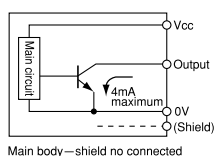

Specifications

Type name		MA□-17-□□□	
Item	Shaft shape ●S=single shaft ●H=hollow shaft	Pulse number	G1 N1 B1
Supply voltage	DC5V ±5%		
Current consumption	70mA or less (under no load)		
Output code	G:gray code, N:Pure binary code, B:BBC code		
Logic	Negative logic (H=0, L=1)		
Resolution	G, N		B
	256 (8 bits) 512(9 bits) 1024 (10 bits)		1000
Output circuit	NPN open collector		
Output capacity	Sink current each bit 4mA (output voltage resistance 7V)		
Allowable load of shaft (electrical)	Radial	1.9N (200gf)	
	Thrust	1.9N (200gf)	
Maximum revolutions	6000r/min		
Maximum response frequency	20kHz		
Starting torque	1×10 ⁻³ N·m(10gf·cm) or less		
Working temperature/humidity	0°C~70°C/RH35%~90% no dewing		
Storage temperature	-20°C~80°C		
Vibration resistance	Durability 55Hz, double amplitude 1.5mm 2 hours each in X, Y, and Z directions		
Impact resistance	Durability 500m/s ² (about 50G) 3 times each in X, Y, and Z directions		
Cable	256:Outside diameter φ3 10-core vinyl wire Insulated shield cable (length 1m)		
	512:1024:1000:Vinyl wire(AWG30) Cable length 300mm		
Mass	30g		

Connection

Type cable color	MA□-17-1024 G1	MA□-17-1024 N1	MA□-17-1000 B1
Black	0V (COMMON)		
Red	5V ±5%		
Brown	Output 2 ⁰		Output 2 ⁰
Brown/black	Output 2 ¹		Output 2 ¹
Orange	Output 2 ²		Output 2 ²
Orange/black	Output 2 ³		Output 2 ³
Yellow	Output 2 ⁴		Output 2 ⁰ ×10
Yellow/black	Output 2 ⁵		Output 2 ¹ ×10
Green	Output 2 ⁶		Output 2 ² ×10
Green/black	Output 2 ⁷		Output 2 ³ ×10
Blue	Output 2 ⁸		Output 2 ⁰ ×10 ²
Blue/black	Output 2 ⁹		Output 2 ¹ ×10 ²
Purple	—		Output 2 ² ×10 ²
Purple/black	—		Output 2 ³ ×10 ²