

MEH-130 series

[Square Wave/Incremental]

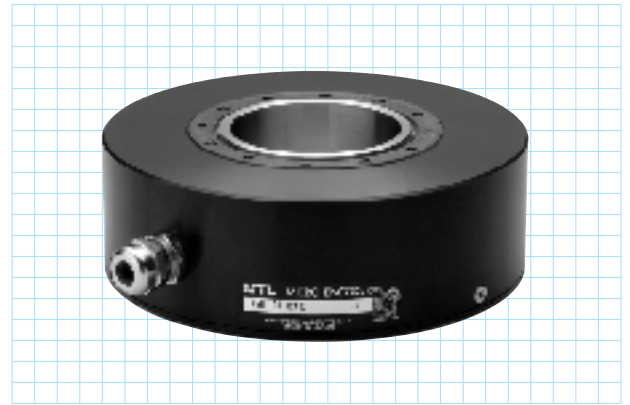

Outside dimensions

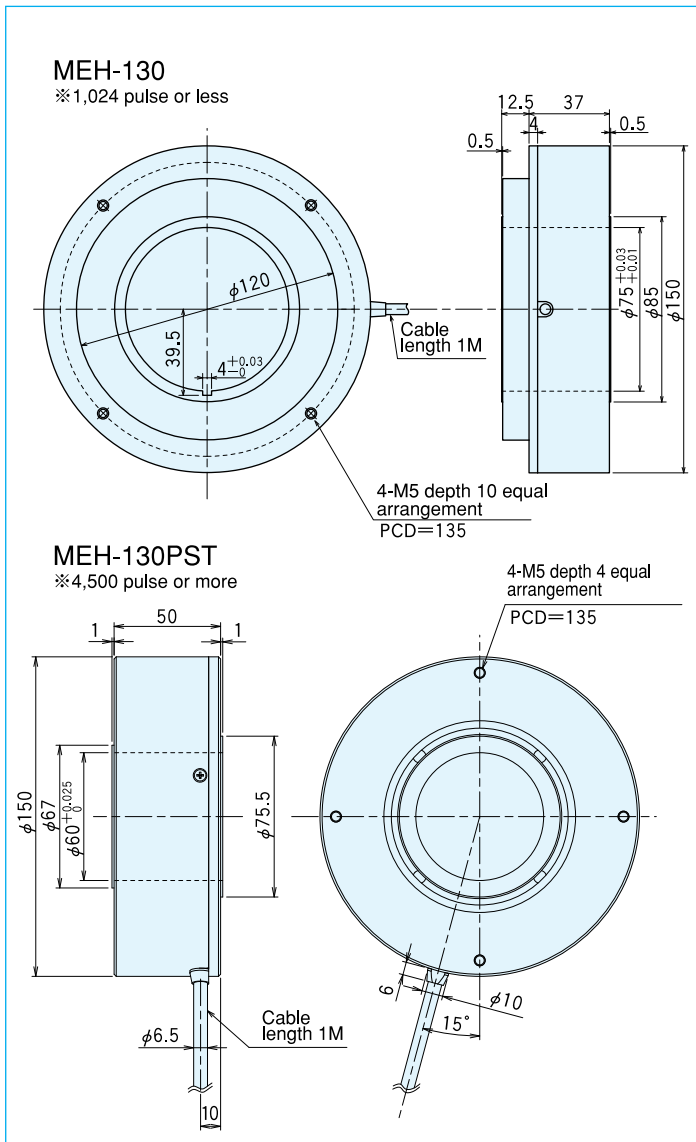

Specifications

Type name	MEH-130-□□	
Item	Pulse number — □□ Output circuit ●No entry=voltage output ●C=open collector output ●C4=open collector output DC24V ●E=line driver output	
Supply voltage/Current consumption	DC5~12V ±10% DC24V±10%(option)	
Detection system	Incremental	
Output	Output pulse number (Standard)	360 9,000 32,400 600 11,250 1,024 20,250 4,500 25,000 5,000 28,125
	Output phase	A, B, Z phase
	Output form	Square wave
	Output capacity	Sink current: 20mA Residual voltage: 0.5V or less (at 10mA)
	Maximum response frequency (response pulse number)	100kHz In case of voltage output, load resistance shall be 2.2kΩ. (Refer to the output circuit diagram.)
Output phase difference	A, B phase difference 90°±45° (T/4±T/8) Z phase T±T/2 (see Output Waveform)	
Waveform rise/fall time	2μs or less (output cable 1m or less)	
Starting torque	50×10 ⁻³ N·m (500gf·cm) or less (no oil seal)	
Allowable load of shaft (electrical)	Radial	19.6N (2kgf)
	Thrust	9.8N (1kgf)
Maximum allowable revolutions (mechanical)	2,000r/min	
Working ambient temperature/humidity	0°C~60°C RH35%~90% no dewing	
Storing ambient temperature	-20°C~80°C	
Vibration resistance	Durability 55Hz, double amplitude 1.5mm 2 hours each in X, Y, and Z directions	
Impact resistance	Durability 500m/s ² (about 50G) 3 times each in X, Y, and Z directions	
Cable	Outside diameter φ6.5 14-core vinyl wire Insulated shield cable (length 1m)	
Mass	3kg	

Output waveform

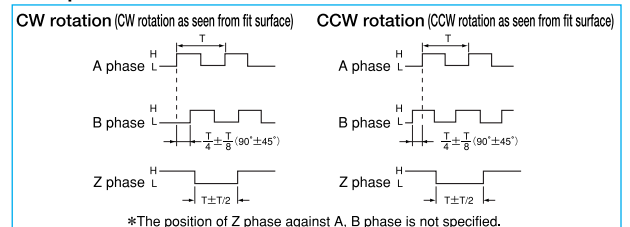

Output circuit diagram

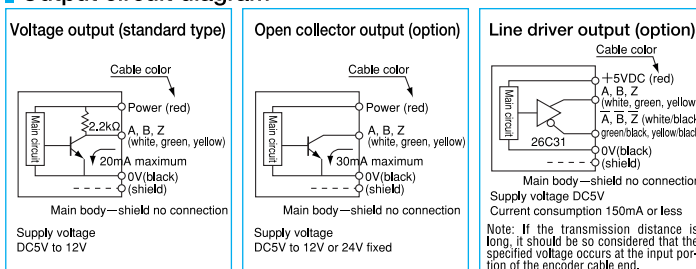

A capacitor (0.1μF) is connected between 0V and FG (frame ground).

Output waveform(E:Line driver)

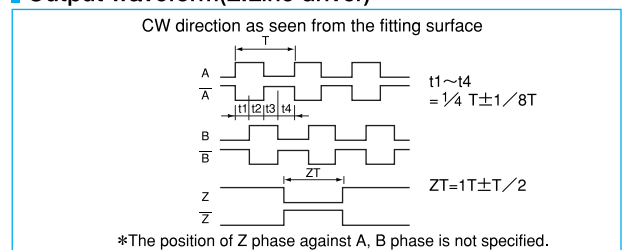

Specifications Built-in multiplication circuit (X2·X4·X8·X16) **NEW**

Supply voltage	Voltage:DC5V-5%~12V+10% Open collector:DC5V-5%~24V+10% Line driver:DC5V±5%	
Current consumption	150mA or less (under no load)	
Detection system	Incremental	
Output	Output pulse number (Standard) [Pulse number/rotation]	EX 32,400×2 (64,800) 32,400×4 (129,600) 32,400×8 (259,200) 32,400×16 (518,400)
	Output phase	A, B, Z phase
	Output form	Square wave
	Maximum response frequency	Line driver output:75kHz× (by multiplication) Voltage output·Open collector output:100kHz
	Output phase difference	See the diagram below.
Starting torque	$50 \times 10^{-3} \text{N} \cdot \text{m}$ (500gf·cm) or less	
Allowable load of shaft (electrical)	Radial	19.6N (2kgf)
	Thrust	9.8N (1kgf)
Maximum allowable revolutions (mechanical)	2,000r/min	
Working ambient temperature/humidity	0°C~60°C RH35%~90% no dewing	
Storing ambient temperature	-20°C~80°C	
Vibration resistance	Durability 55Hz, double amplitude 1.5mm 2 hours each in X, Y, and Z directions	
Impact resistance	Durability 500m/s ² (about 50G) 3 times each in X, Y, and Z directions	
Cable	Outside diameter $\phi 6.5$ 14-core vinyl wire Insulated shield cable (length 1m)	
Mass	3kg	

Output circuit diagram

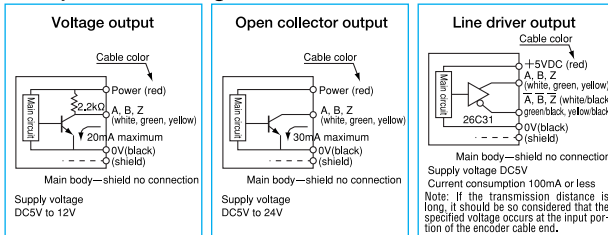

A capacitor (0.1 μF) is connected between 0V and FG (frame ground).

Output waveform

