

MES-40-P series

[Square Wave/Incremental]

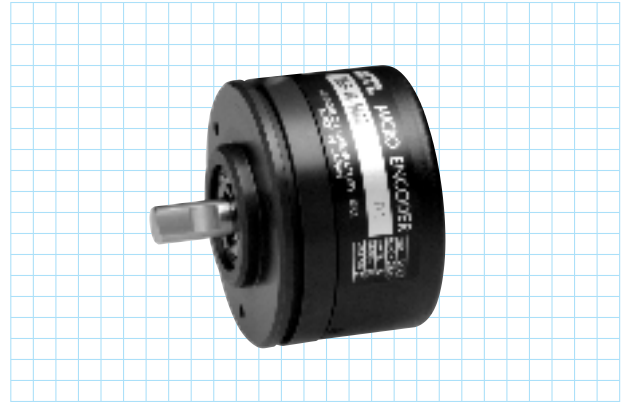

Outside dimensions

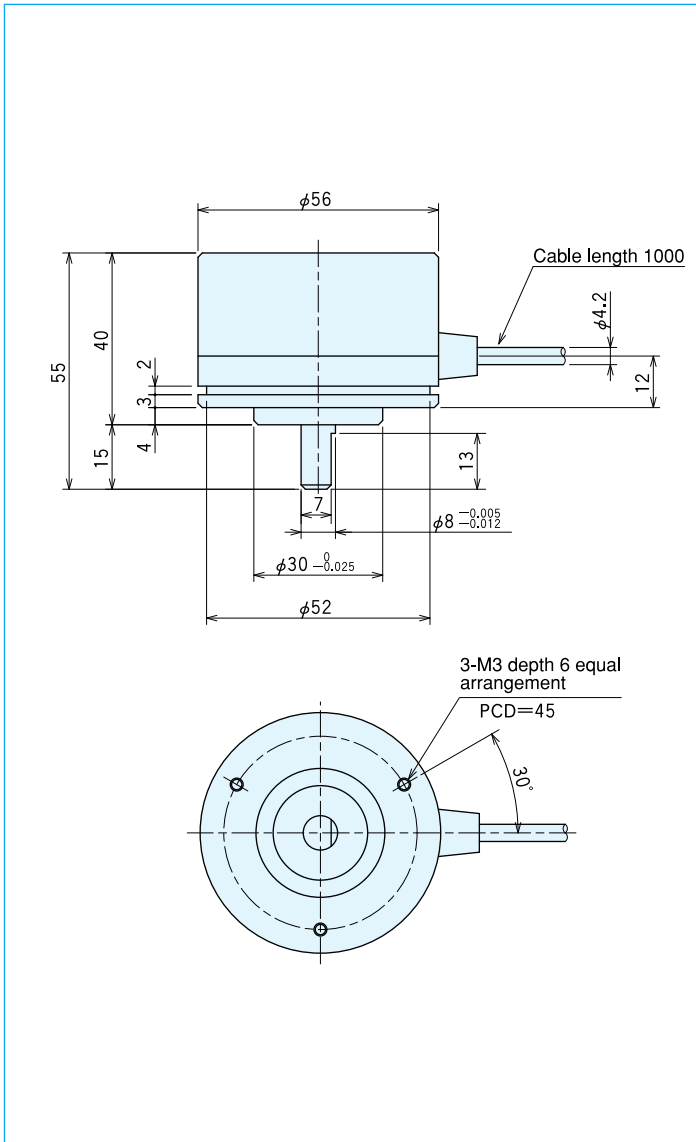

Specifications

Type name		MES-40-□ P□	
Pulse number		<ul style="list-style-type: none"> ● No entry= voltage output ● C= open collector output ● C4= open collector output DC24V ● E= line driver output ● S= sine wave output ● ST= built-in multiplication circuit ● P2= two head detection 	
Item			
Supply voltage		DC5~12V ±10% DC24V±10% (option)	
Current consumption		40mA or less (under no load)	
Detection system		Incremental	
Output pulse number (Standard)		100	1,000
[Pulse number/rotation]		200	1,024
		360	2,000
		500	3,600
		512	4,000
		600	4,094
		5,000	5,400
		6,000	6,000
		8,192	9,000
		10,800	11,250
		15,000	
Output phase		A, B, Z phase	
Output form		Square wave	
Output capacity		Sink current: 20mA Residual voltage: 0.5V or less (at 10mA)	
Maximum response frequency (response pulse number)		100kHz	
Output phase difference		A, B phase difference 90°±45° (T/4±T/8) Z phase T±T/2 (see Output Waveform)	
Waveform rise/fall time		2μs or less (output cable 1m or less)	
Starting torque		3×10 ⁻³ N·m (30gf·cm) or less 5×10 ⁻³ N·m (50gf·cm) or less (drip-proof)	
Allowable load of shaft (electrical)	Radial	49N (5kgf)	
	Thrust	29.4N (3kgf)	
Maximum allowable revolutions (mechanical)		6,000r/min	
Working ambient temperature/humidity		-10°C~70°C RH35%~90% no dewing	
Storing ambient temperature		-20°C~80°C	
Vibration resistance		Durability 55Hz, double amplitude 1.5mm 2 hours each in X, Y, and Z directions	
Impact resistance		Durability 500m/s ² (about 50G) 3 times each in X, Y, and Z directions	
Cable		Outside diameter φ4.2 5-core vinyl wire Insulated shield cable (length 1m)	
Mass		200g	

Output circuit diagram

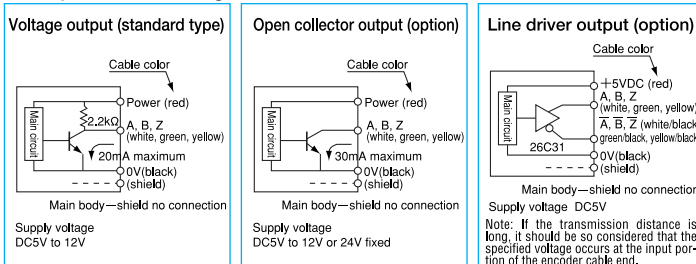

A capacitor (0.1μF) is connected between 0V and FG (frame ground).

Output waveform

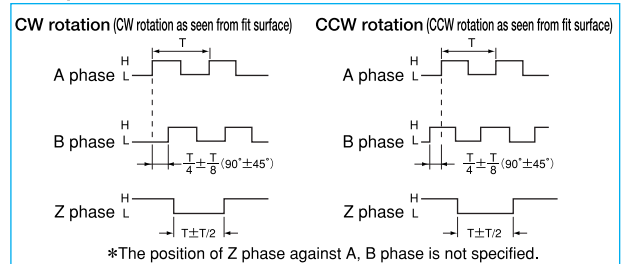

Specifications/Sine wave

Supply voltage	DC5V ±5%	
Current consumption	40mA or less (under no load)	
Detection system	Sine wave·Incremental	
Output pulse number (Standard) [Pulse number/rotation]	1,000	
	2,000	
Output phase	A, B, Z phase	
Output form	A, B phase SIN wave, Z phase square wave	
A, B, Z phase output	SIN wave 1.5 Vp-p±0.3 V offset 2.0V±0.2V	
	Opamp output current 5mA Max.	
	Harmonic distortion factor to be within 10% (Measuring condition to be within 20 kHz, effective value mean distortion factor measuring instrument)	
Maximum response frequency	50kHz	
Output phase difference	A, B phase difference 90°±45° (T/4±T/8) Z phase T±T/2 (see Output Waveform)	
Starting torque	3×10 ⁻³ N·m (30gf·cm) or less 5×10 ⁻³ N·m (50gf·cm) or less (drip-proof)	
Allowable load of shaft (electrical)	Radial	49N (5kgf)
	Thrust	29.4N (3kgf)
Maximum allowable revolutions (mechanical)	6,000r/min	
Working ambient temperature/humidity	0°C~50°C RH35%~90% no dewing	
Storing ambient temperature	-20°C~80°C	
Vibration resistance	Durability 55Hz, double amplitude 1.5mm 2 hours each in X, Y, and Z directions	
Impact resistance	Durability 500m/s ² (about 50G) 3 times each in X, Y, and Z directions	
Cable	Outside diameter φ4.2 5-core vinyl wire Insulated shield cable (length 1m)	
Mass	200g	

Output

Specifications Built-in multiplication circuit (X4·X8·X16)

Supply voltage	Voltage:DC5V-5%~12V+10% Open collector:DC5V-5%~24V+10% Line driver:DC5V±5%	
Current consumption	80mA or less (under no load)	
Detection system	Incremental	
Output	Output pulse number (Standard) [Pulse number/rotation]	EX 5,000×4 (20,000) 5,000×8 (40,000) 5,000×16 (80,000)
	Output phase	A, B, Z phase
	Output form	Square wave
	Maximum response frequency	Line driver output:50kHz× (by multiplication) Voltage output·Open collector output:100kHz
Output phase difference	See the diagram below.	
Starting torque	3×10 ⁻³ N·m (30gf·cm) or less 5×10 ⁻³ N·m (50gf·cm) or less (drip-proof)	
Allowable load of shaft (electrical)	Radial	49N (5kgf)
	Thrust	29.4N (3kgf)
Maximum allowable revolutions (mechanical)	6,000r/min	
Working ambient temperature/humidity	-10°C~70°C RH35%~90% no dewing	
Storing ambient temperature	-20°C~80°C	
Vibration resistance	Durability 55Hz, double amplitude 1.5mm 2 hours each in X, Y, and Z directions	
Impact resistance	Durability 500m/s ² (about 50G) 3 times each in X, Y, and Z directions	
Cable	Outside diameter φ4.2 5-core vinyl wire Insulated shield cable (length 1m)	
Mass	200g	

Output circuit diagram

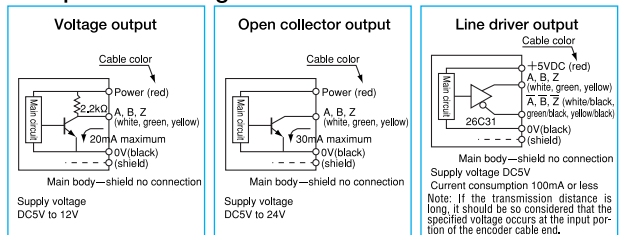

A capacitor (0.1μF) is connected between 0V and FG (frame ground).

Output circuit diagram

Sine wave output (option)

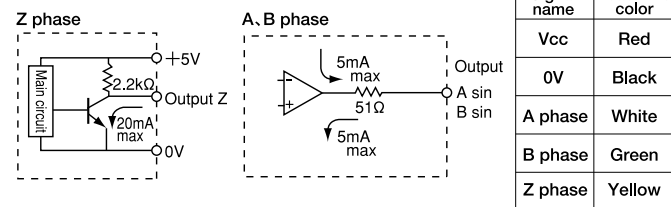

A capacitor (0.1μF) is connected between 0V and FG (frame ground).

Output waveform

Sine wave output (option)

CW rotation (CW rotation as seen from fit surface)

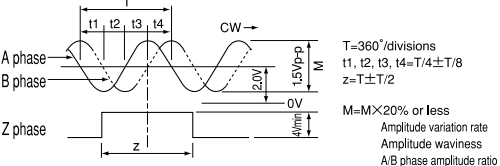

*The position of Z phase against A, B phase is not specified.

Output waveform

CW rotation (CW rotation as seen from fit surface)

